

Industrial X-Ray Tube



PRODUCT DESCRIPTION

The EG-50 series of beryllium window X-Ray tubes are designed for use as radiation sources in energy-dispersive fluorescence analysis systems.

- EG-50E, EG-50H

These various versions of tubes differ in beryllium window thickness - as indicated by the presence of a suffix (see SPECIFICATION - Inherent Filtration).

A variety of target materials are available (see SPECIFICATION). These tubes can operate at voltages as low as 5 kVcp.

The X-Ray beam is perpendicular to the target, providing a very uniform cone of radiation over a wide angle. This feature allows short focal spot-to-sample distances.

Maximum X-Ray intensity is achieved by use of a thin beryllium window which is the only element of inherent filtration.

PRODUCT DESCRIPTION

The cathode is designed for operation at ground potential:

- eliminating the need for a highly insulated filament transformer; and
- eliminating electron bombardment of the beryllium window and the resultant heating.

Most tube enclosures require some type of forced cooling (usually oil-water or forced oil) to maintain oil temperature below 150°F (65°C) at maximum ratings. The highest oil temperature occurs next to the anode, particularly in the glass re-entrant cavity surrounding the anode. Circulating oil circulation in this area extends the tube life especially when the tube is operated anode down.

The X-ray window is located at the end of the tube, and the X-ray beam is projected along the longitudinal axis of the tube.

SPECIFICATIONS

Rating Chart:	Tube Type	kVcp	mA*
	EG-50 Series	50	4.0

(* for lower values of kVcp, the mA may be increased proportionally except as limited by the maximum allowable filament current.)

Target Angle: 90° from central ray

Anode Dissipation: 200 watts (maximum)

Focal Spot: Round focal spot approximately 6mm in diameter

Filament Characteristics:

3.3 volts, maximum

8.8 amperes, maximum

(except as limited by maximum power capability) SEE EMIS-
SION CHART

Note (1) The high-voltage circuit should contain at least 1 ohm
of added resistance for each volt of maximum operating voltage.

Note (2) All tubes incorporate a ceramic cathode insulator
which make them compatible for use in helium spectrometers.

Maximum Bulk Oil Temperature: 150°F (65°C)

Weight: Approximately 1 lb. (.5 kg)

SPECIFICATIONS

Envelope: Concentric metal cathode ring surrounding a beryllium X-
ray window, and a hard glass section to support and insulate the anode.

Anode: Vacuum cast copper with target as specified below.
External metal surfaces dull nickel plated.

Radiation Characteristics		
Tube Type	Inherent Filtration (Beryllium Window Thickness)	Radiation Cone (Unshadowed)
EG50E	.030 [.76] mm	30°
EG50H	.005 [.13] mm	25°

Standard Target Materials:

Molybdenum (Mo), Tungsten (W), Rhodium (Rh), Platinum (Pt),
Titanium (Ti)

Cathode: Circular tungsten filament concentric with axis of anode
and X-ray window.

Cooling Method: Convection in surrounding insulating medium.

Insulating Medium:

Oil with minimum dielectric strength of 30 kV rms per 0.1 inch, as
measured by ASTM Standard Test No. D-877

ORDERING NOTES

Refer to Varian price list. When ordering specify:

- beryllium window thickness (by using appropriate suffix
- see SPECIFICATION - Inherent Filtration)
- target material (see SPECIFICATIONS - Standard Target
Materials)

WARNING

Beryllium windows permit a very high level of long wavelength X-radiation to pass through, which can
cause injury to humans.

Injury may occur from even very short exposures to the primary X-ray beam.

Follow all precautions necessary to avoid radiation exposure to humans.

NOTE: The radiation dosage rate cannot be accurately measured with conventional radiation measurement
instruments. Radiation intensity in each installation will vary, and calibration must include the effects of
long wavelength X-radiation.

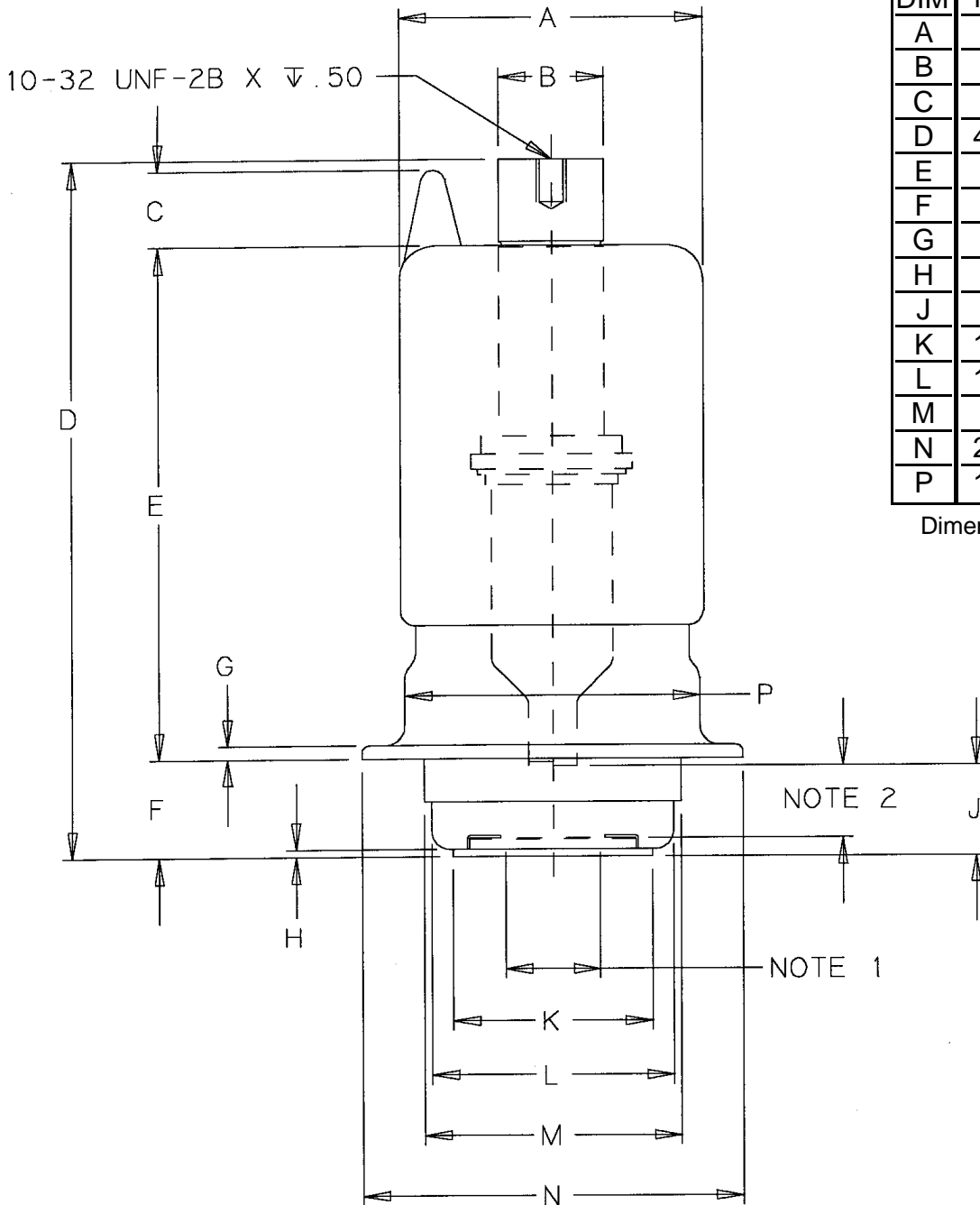

DIM	MIN	MAX	REF
A		2.00	
B	.68	.72	
C		.50	
D	4.57	4.65	
E		3.41	
F	.64	.69	
G	.08	.10	
H		.06	
J	.57	.66	
K	1.29	1.33	
L	1.58	1.60	
M			1.69
N	2.48	2.52	
P	1.93	1.95	

Dimensions are in inches

Notes:

1. Be WINDOW MIN. CLEAR WINDOW .625" (15.87mm) H WINDOW AND .825" (20.95mm) E WINDOW.
2. ANODE TO BACK OF Be WINDOW .481" (12.22mm)

FILAMENT EMISSION CHARACTERISTICS

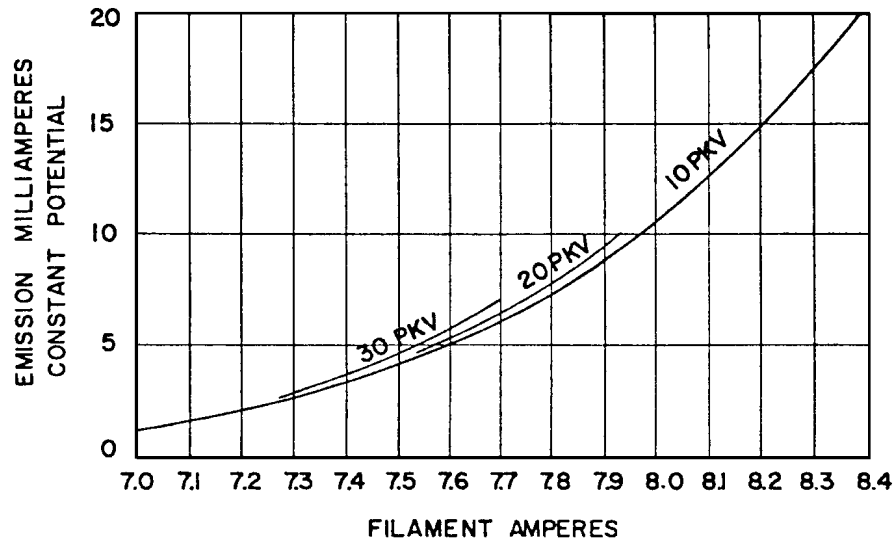

FILAMENT VOLT-AMP CHARACTERISTICS

