

Tubes Radiogènes à Anode Tournante
Drehanoden - Röntgenröhre
Tubos de Rayos-X con Ánodo Giratorio

Note: Document originally drafted in the English language.

Product Description	Description du Produit	Produktbeschreibung	Descripción del Producto
<p>The GS-2096 is a 5.2" (133 mm) 150 kV, 1.43 MJ (2.0 MHU) maximum anode heat content, rotating anode insert. This insert is specifically designed for CT Scanner. The insert features a 12° tungsten-rhenium facing on molybdenum with a graphite backed target and is available with the following nominal focal spots:</p> <p style="text-align: center;">0.6 x 0.9 1.4 x 1.8 IEC 60336</p> <p>Loading Factor for slit focal: Small - 120 kV, 100 mA Large - 120 kV, 200 mA</p> <p>Maximum Anode Cooling Rate: 4,000 W (5,600 HU/sec)</p> <p>Maximum continuous anode heat dissipation: 3,000 W (4,200 HU/sec)</p> <p>Nominal Anode Input Power: Small - 16 kW IEC 60613 Large - 32 kW IEC 60613</p> <p>Reference Angle: Perpendicular to port face.</p> <p>This insert is intended for use in a Varian B-225H housings.</p>	<p>Le tube GS-2096 est une tube à anode tournante de plateau 133mm, (5,2 pouces), 150 kV, d'une capacité thermique de 1,43 MJ (2,0 MUC). Il est spécialement conçu pour une utilisation avec les scanners CT. Le tube est pourvu d'une anode avec pente de 12° en rhénium-tungstène sur une base de molybdène et avec un doublage de graphite. Il est disponible avec les foyers suivants:</p> <p style="text-align: center;">0,6 x 0,9 1,4 x 1,8 CEI 60336</p> <p>Facteur de charge pour foyer à fente: Petit - 120 kV, 100 mA Grand - 120 kV, 200 mA</p> <p>Toux maximum de refroidissement de l'anode: 4,000 W (5,600 UC/sec)</p> <p>Description calorifique maximim de l'anode (en continu): 3,000 W (4,200 UC/sec)</p> <p>Puissance Nominale de l'anode: Petit - 16 kW CEI 60613 Grand - 32 kW CEI 60613</p> <p>Référence Axe: Perpendiculaire à la face de sortie.</p> <p>Ce tube est essentiellement destiné à être employé dans les gaines Varian des séries B-225H.</p>	<p>Die GS-2096 ist eine 133 mm (5.2") Doppelfokus Drehanoden-Röntgenröhre, mit einer Anoden Wärmespeicherkapazität von 1.43 MJ (2.0 MHU) und einer max. Spannungsfestigkeit von 150 kV. Die Röntgenröhre wurde für den Einsatz an CT entwickelt. Der rückseitig graphitebeschichtete Wolfram Rhenium-Molybdän Anodenteller besitzt einen Winkel von 12°. Folgende Brennfleckkombination ist lieferbar:</p> <p style="text-align: center;">0.6 x 0.9 1.4 x 1.8 IEC 60336</p> <p>Ladefaktor: Klein -120 kV, 100 mA Gross - 120 kV, 200 mA</p> <p>Nennleistung der Anode: 4,000 W (5,600 HU/sek)</p> <p>Maximale kontinuierliche Wärmeableitung der Anodentellers: 3,000 W (4,200 HU/sek)</p> <p>Nominale Anoden Eingangsleistung: Klein - 16 kW IEC 60613 Gross - 32 kW IEC 60613</p> <p>Referenz-Achsen: Senkrecht zum Strahlenaustrittsfenster.</p> <p>Die Röntgenröhre ist für den Einbau in die Varian Strahlerhaube B-225H vorgesehen.</p>	<p>El GS-2096 es un tubo de ánodo giratorio de 133 mm (5.2"), 150 kV, 1.43 MJ (2.0 MHU), la cual es el máximo almacenaje termal del anodo. Es diseñado específicamente para uso en CT Scanners. El blanco emisor es una combinación de tungsteno, renio y molibdeno con grafito en la parte posterior con un rayo central de 12 grados. Disponible con las siguientes combinación de marcas focales:</p> <p style="text-align: center;">0.6 x 0.9 1.4 x 1.8 IEC 60336</p> <p>Carga Electrica Para la Abertura Focal: Pequeño -120 kV, 100 mA Grande - 120 kV, 200 mA</p> <p>Medida Maxima del Enfriamiento del Anodo: 4,000 W (5,600 HU/seg)</p> <p>Maxima disipación termal continuo del Anodo: 3,000 W (4,200 HU/seg)</p> <p>El Poder de Penetración para el Anodo Nominal: Pequeño - 16 kW IEC 60613 Grande - 32 kW IEC 60613</p> <p>Angula de Referencia: Perpendicular a la abertura facial.</p> <p>Este tubo es diseñado, para uso en los encajes Varian de la serie B-225H.</p>

Manufactured by Varian Medical Systems
Fabrique par Varian Medical Systems
Hergestellt von Varian Medical Systems
Fabricado por Varian Medical Systems

Specifications subject to change without notice.
Spécifications susceptibles d'être modifiées sans préavis.
Technische Daten ohne Gewähr.
Especificaciones sujetas a cambio sin previo aviso.

3 Ø Constant Potential

Abaques de Expositions CEI 60613
Belastungskurven IEC 60613
Diagramas de Exposición IEC 60613

50/60 Hz

0.6 X 0.9 

1.4 X 1.8 

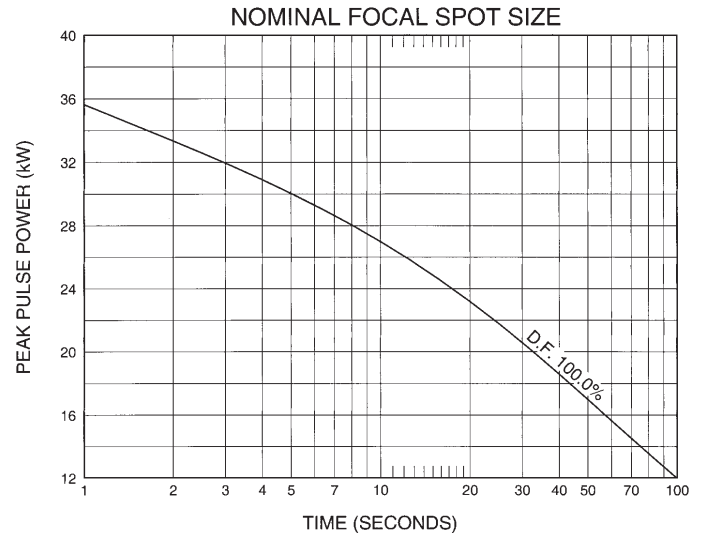
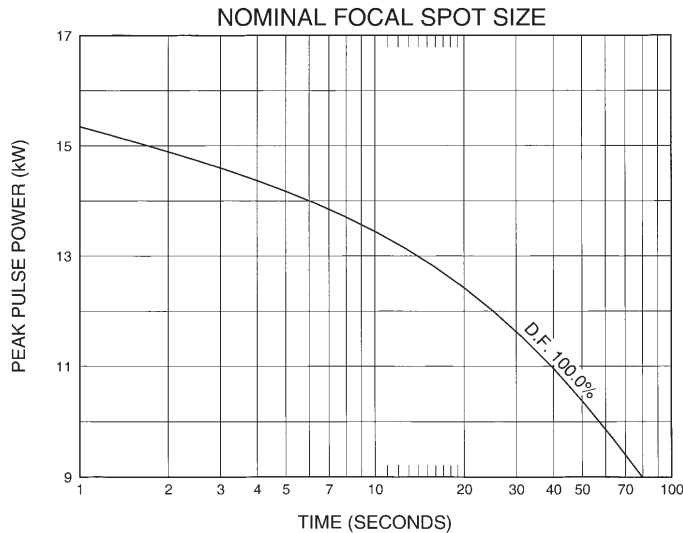

150/180 Hz

0.6 X 0.9 

1.4 X 1.8 

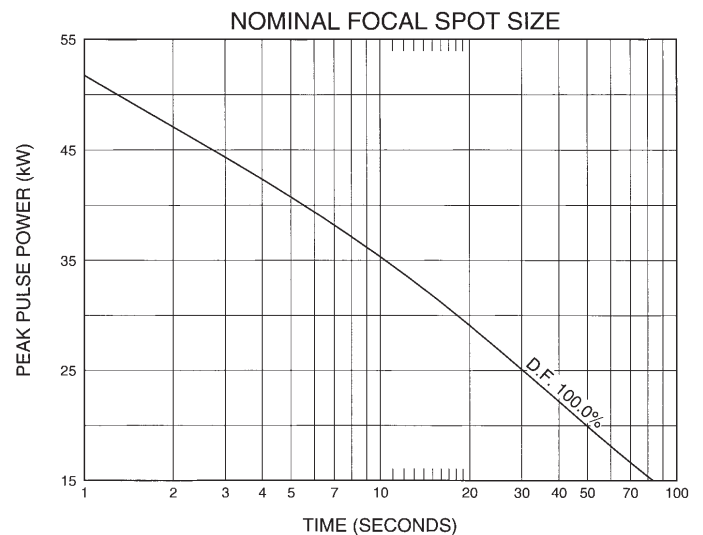
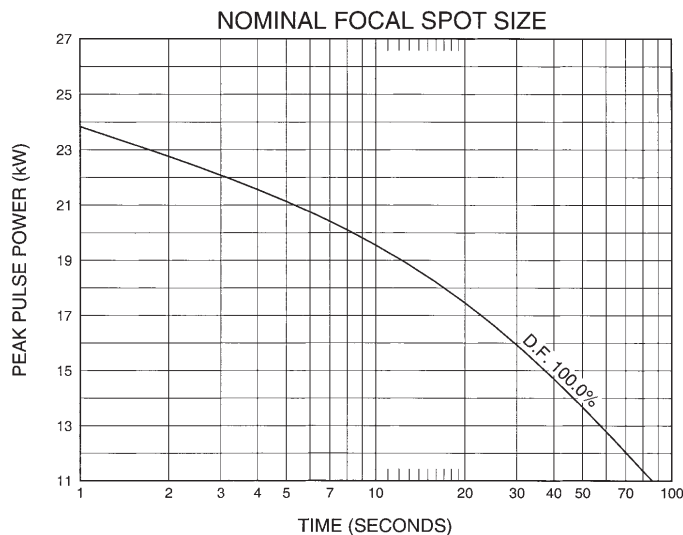

Note:
Rating charts reflect maximum tube performance. Tube operation is ultimately limited by system software.

Remarque:
Abaques de caractéristiques représentent des valeurs maximales. L'utilisation du tube est finalement limitée par le logiciel du système.

Anmerkungen:
Die Leistungskurven zeigen die maximale Röhrenleistung. Der Röhrenbetrieb ist ultimativ zu begrenzen durch die Systemkontrollsoftware.

Nota:
El máximo poder del tubo es reflectada en el clasificación diagrama. La operación del tubo es ultimamente limitada por el control del sistema programado.



Caractéristiques d'Émission du Filament CEI 60613
Kathoden - Emissionskennlinien IEC 60613
Características de Emisión del Catodo IEC 60613

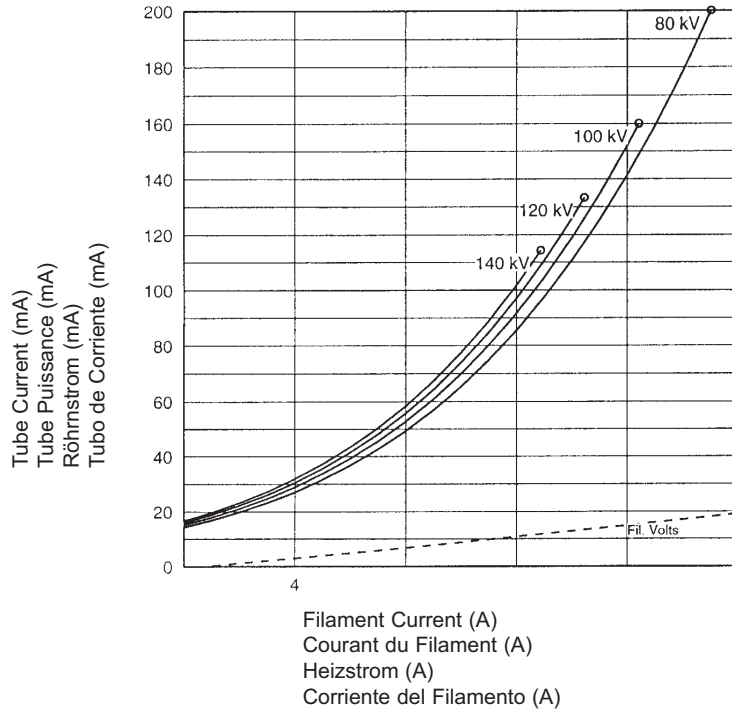

THREE PHASE EMISSION (± .15 A)
GS-2096 0.6 x 0.9

Filament Voltage (V)
Voltage du Filament (V)
Heizspannung (V)
Voltaje en los Filamentos (V)

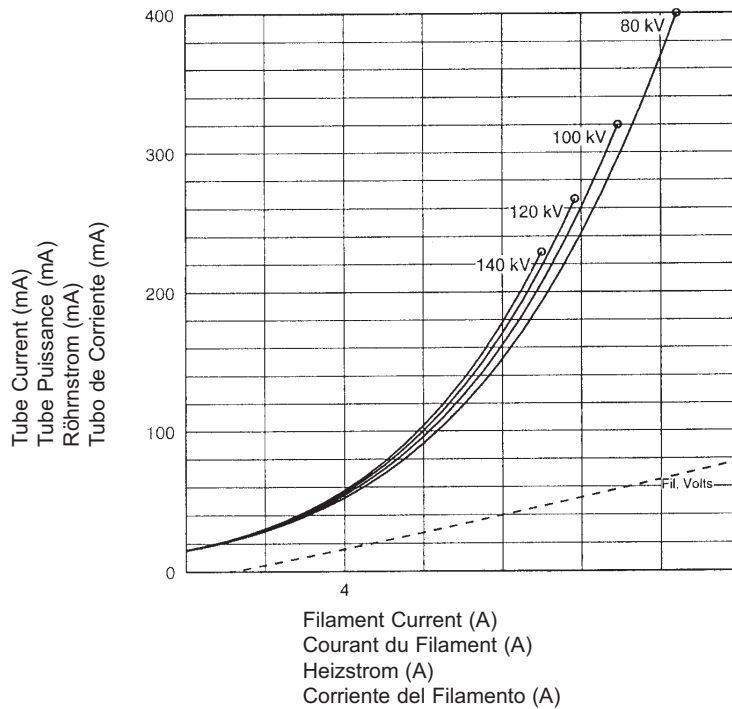

THREE PHASE EMISSION (± .15 A)
GS-2096 1.4 x 1.8

Filament Voltage (V)
Voltage du Filament (V)
Heizspannung (V)
Voltaje en los Filamentos (V)

Le Gaine B-225H

Das B-225H Gehäuse

Encaje de B-225H

Maximum Peak Voltage	150 kV
Anode to Ground	75 kV
Cathode to Ground	75 kV
Maximum X-ray Tube Assembly Heat Content	1.5 MJ (2.0 MHU)
Maximum Continuous Heat Dissipation (max. housing temperature 78°C) (Includes stator heat)	3,800 W (5,300 HU/sec)
Maximum Heat Exchanger Dissipation	5,000 W (7,050 HU/sec)
Focal Point Position (Central Ray) Within 1mm (X,Y Direction from the center of radiation port.)	
X-Ray Tube Assembly	
Permanent filtration	1.0 mm Al IEC 60522
Loading Factors for Leakage Radiation	150 kV, 20 mA
Federal Standard High Voltage Cable	72
Ambient Air Temperature Limits for Operation	5°C to 40°C
Temperature Limits for Storage and Transport	-20°C to +75°C
Humidity	+10% to +90%
Atmospheric Pressure Range	70 kPa to 106 kPa
Weight: Housing	35.5 kg (78 lbs)
Heat Exchange	17 kg (38 lbs)
IEC Classification	Class 1
Safety Devices: Thermal Switch - Normally Closed Contact Opening at 85°C ±3°C	
Flow Switch: Normally Open Contacts Contacts close with adequate oil flow.	
Filament Frequency Limits	50 HZ - 20 KHZ
Power Supply	DC

Maximale Spannungsfestigkeit	150 kV
Anode gegen Erde	75 kV
Kathode gegen Erde	75 kV
Maximale Wärmespeicherkapazität des Strahlergehäuses ..	1.5 MJ (2.0 MHU)
Maximale kontinuierliche Wärmeableitung des Strahlergehäuses (max. Gehäuse-temperatur 78°C) (einschließlich Statorerwärmung)	3,800 W (5,300 HU/sec)
Maximale Wärmeaustauscher - Verlustleistung	5000 W 7,050 HU/sec)
Brennfleckposition (Zentralstrahl) innerhalb 1mm (x-,y-Achse von der Mitte des Strahlaustrittsfensters)	
Röntgenstrahlers	
Eigenfilterwert	1.0 mm Al IEC 60522
Ladefaktoren für Leckstrahlungsmessung	150 kV, 20 mA
Federal Standard Hochspannungsbuchsen	72
Umgebungstemperaturgrenzen für den Betrieb	5°C bis 40°C
Temperaturgrenzen für Aufbewahrung und Transport	-20°C bis +75°C
Feuchtigkeit	+10% bis +90%
Luftdruck	70 kPa bis 106 kPa
Gewicht: Gehäuse	35.5 kg (78 lbs)
Wärmespeicherung	17 kg (38 lbs)
IEC Klassifizierung	Klasse 1
Sicherheitseinrichtungen: Thermoschalter normalerweise geschlossen Verbindung	Offen bei 85°C ±3°C
Strömungsschalter - Kontakte normalerweise Offen. Kontakte schließen sich bei ausreichendem Ölfluß.	
Heizfaden - Frequenzgrenze	50 HZ - 20 KHZ
Netzanschluß	DC

Voltage Maximum	150 kV
Tensión Anode - Terre	75 kV
Tension Cathode - Terre	75 kV
Capacité Thermique Maximale de L'Ensemble Tube/Gaine ..	1,5 MJ (2,0 MUC)
Dissipation thermique continue de la gaine (température maximale de la gaine à 78°C) (Inclut la chaleur statorique)	3,800 W (5,300 UC/sec)
Dissipation Maximale de l'échangeur de chaleur	5,000 W (7,050 UC/sec)
Position du foyer (rayon central) à 1mm près (Coordonnées X,Y par rapport au centre du port de rayonnement.)	
Ensemble Radiogène	
Filtre non amovible	1,0 mm Al CEI 60522
Facteur de Charge Poru Rayonnement de fuite	150 kV, 20 mA
Embouts de Cables au Standard Federal	72
Température Ambiante Pendant L'usage	5°C à 40°C
Limites de Température Pour le Transport et Pour L'Emmaseinage	
Humidité	-20°C à +75°C
Humidité	+10% à +90%
Limites de pression atmosphérique	70 kPa à 106 kPa
Poids: Gaine	35,5 kg (78 lbs)
Échangeur de Chaleur	17 kg (38 lbs)
Classification CEI	Classe 1
Dispositifs de Sécurité Thermique	
Normalement Fermé	Ouverture du Contact à 85°C ±3°C
Contacteur de débit - Contacts normalement ouverts Contacts fermés en présence d'un débit d'huile adéquat.	
Limites de fréquence des filaments	50 HZ - 20 KHZ
Alimentation Demandée	Courant Continu

Voltage Maximo Elevado	150 kV
Anodo a Tierra	75 kV
Catodo a Tierra	75 kV
Maximo Calor Contenido Ensamblaje del Tubo de Rayos X	1.5 MJ (2.0 MHU)
Difusion del calor continuo del encaje (temperatura máxima de la encaje 78°C) (Incluye el calor de la bobina)	3,800 W (5,300 HU/sec)
Disipación maxima del radiador	5,000 W (7,050 HU/sec)
Posición de la marca focal (Rayo Central) Dentro de 1mm. (La dirección axial X, Y se refiere del centro de la radiación portal.)	
Ensamblaje de Tubo de Rayos X	
Filtración Permanente	1.0 mm Al IEC 60522
Especificaciones de Encaje para la fuga de Radiacion	150 kV, 20 mA
Cable de Receptaculos Comun Federal	72
Temperatura Limitada de Operación	5°C a 40°C
Temperatura Limitada de Almacen y Transporte	-20°C a +75°C
Humedad	+10% a +90%
Limites de la presión atmosférica	70 kPa a 106 kPa
Peso: Encaje	35.5 kg (78 lbs)
Radiador	17 kg (38 lbs)
IEC Clasificación	Clase 1
Aparatos de Seguridad: Interruptor Termal Normalmente Cerrado	Abierto a 85°C ±3°C
Flow Switch: Normalmente los contactos estan abiertos Contactos cerrados con adecuado flujo Aceite.	
Limites de la frecuencia del filamento	50 HZ - 20 KHZ
Suministrador-de-Poder	Corriente Directa

Le Gaine B-225H

Das B-225H Gehäuse

Encaje de B-225H

Dimensions are for reference only
Les dimensions sont pour la référence seulement
Maße sind als nur Referenz
Las dimensiones están para la referencia solamente

Note: Dimensions in Inches
Remarque: Dimensions en Pouces
Hinweis: Abmessungen in Zoll
Nota: Dimensiones en Pulgadas

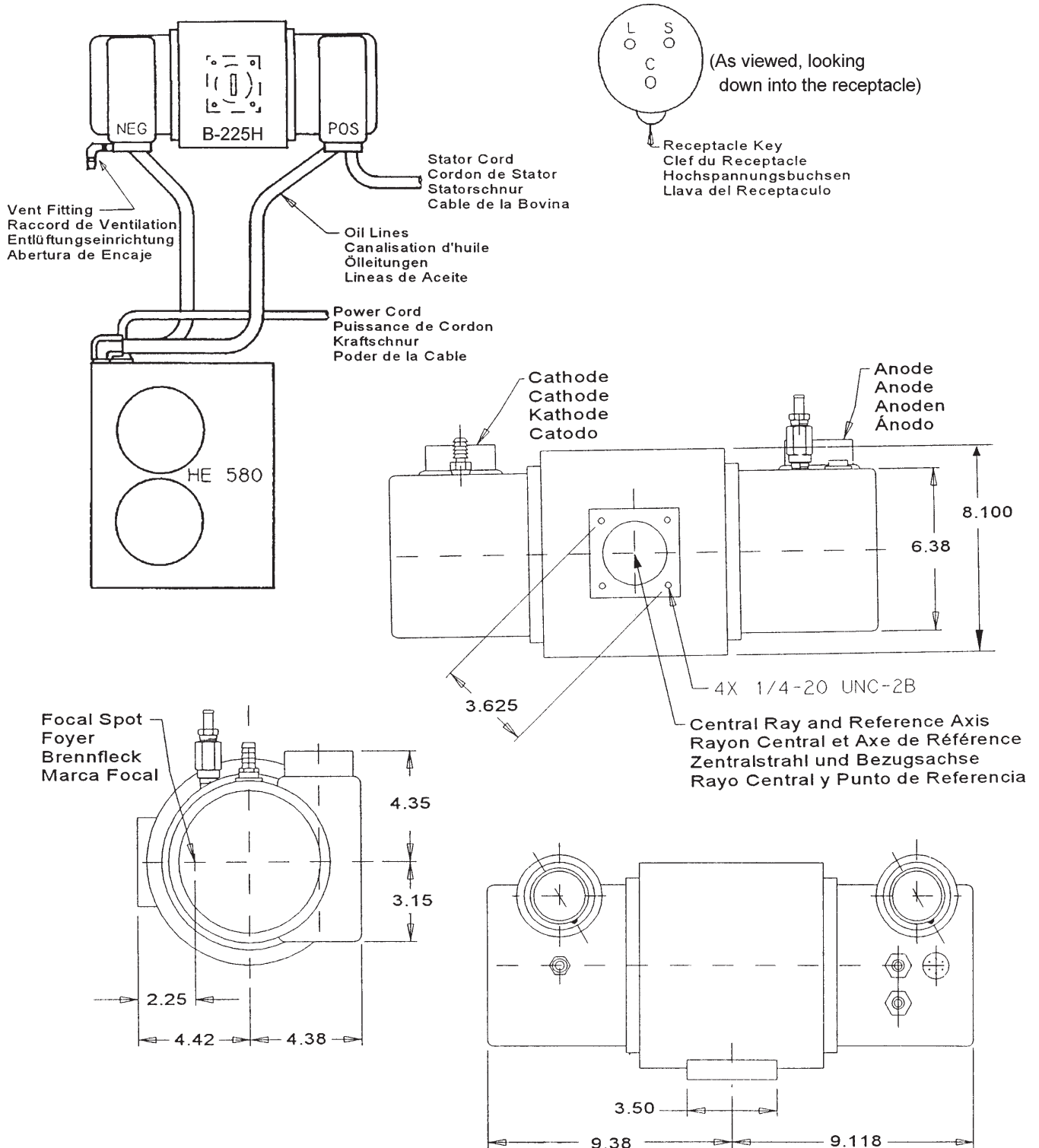

Échauffement et Refroidissement de l'Ensemble CEI 60613
Röhrengehäusebaugruppe Aufheizung und Abkühlung IEC 60613
Enfriamiento y Calentamiento del Encaje Asamblado IEC 60613

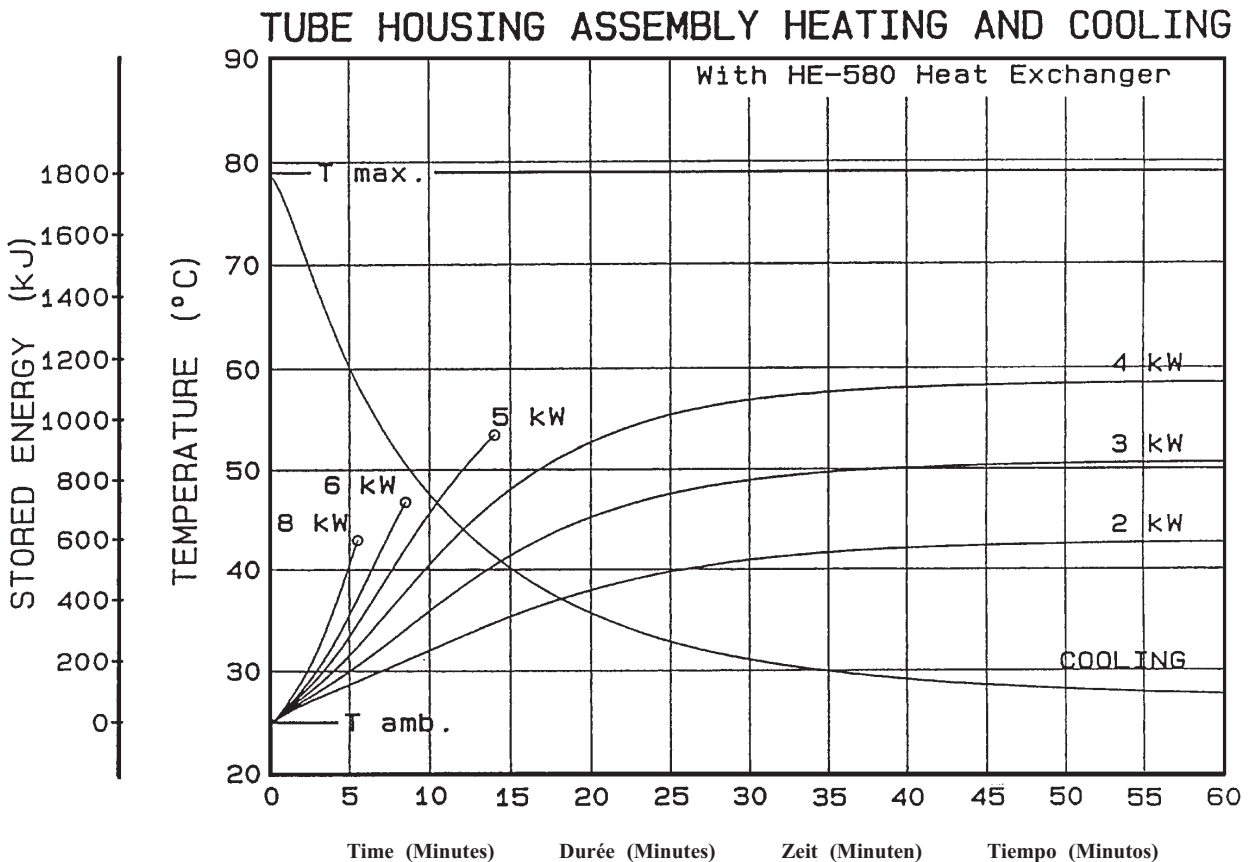

Note:

- Heat inputs into housing include tube power, filament power, and stator power.
- Heating curves based on no restrictions of natural convection around tube housing assembly.
- Heating and cooling curves reflect maximum tube performance. Tube operation is ultimately limited by system software control.

Remarque:

- L'apport calorifique dans la gaine inclut la puissance du tube, du filament et du stator.
- Courbes d'échauffement basées sur une circulation d'air naturelle sans entrave autour de l'ensemble gaine-tube.
- Les abaques d'échauffement et de refroidissement représentent des valeurs maximales. L'utilisation du tube est finalement limitée par le logiciel du système.

Anmerkungen:

- Die Erwärmungskurven berücksichtigen die Verlustleistung aus der Anode, der Kathode und des Stators.
- Die Heizkurven basieren auf keinerlei Einschränkung der natürlichen Konvektion in der Umgebung der Strahlerhaube.
- Die Angaben stellen die höchstzulässigen Betriebswerte dar. Der technische Betrieb muß im Rahmen der Belastungs- und Abkühlkennlinien erfolgen.

Nota:

- La energía del encaje incluye el poder del tubo, el poder del filamento y el poder de la bovina.
- Las curvas de calentamiento no son afectadas por el calor natural creado en la parte exterior del encaje.
- El máximo poder del tubo es reflectada en el diagrama de enfriamiento y calentamiento del tubo es ultimamente limitada por el control del sistema programado.

To install the Varian housing on Picker Scanners certain trunnion mount parts must be replaced. The replacement parts contained in trunnion assembly kit, catalog #CN-184.

The “adjuster” base plate under Picker trunnion ring assembly is retained for use with the Varian trunnion ring base plate.

**B-225H Housing and HE-580 Exchanger
Installation**

Refer to Figure 1 (CN-184 Trunnion Rings)

1.0 Install Base Plate to Heat Exchanger

1.1 Install mounting plate, Item 7, to heat exchanger using spacers and screws, Items 8 and 9, supplied. See Figure #1 (studs on plate face away from heat exchanger). **Locktight is required on all Heat Exchanger hardware.**

2.0 Preassemble Trunnions

2.1 Assemble bottom half of trunnion rings, Items 2 and 10 to base plate, Item 1. Note Item 10 is mounted to front of base plate. See Figure #1. Use four 5/16” x 3/4” cap head screws (Item 5), supplied. Do not tighten.

2.2 Temporarily position trunnion mounting bracket and rings on housing. **Use plate trunnion liners.** Tighten four screws (Item 4) holding trunnion rings to mounting bracket allowing small anode - to - cathode motion between rings and housing.

3.0 Installation of Trunnion Mount to Gantry

3.1 Remove trunnion mount from housing and install on gantry “adjuster base plate” with four original 5/8” bolts.

NOTE: Check clearance between base plate and encoder head read cable. If necessary, the cable can be rerouted under the encoder block.

4.0 Adjusting Plate

4.1 In-out adjusting plate, Item 3. Assemble adjusting screw (Item 12), to adjusting tongue, Item 3, supplied and base plate, Item 1. Fasten adjusting tongue to the adjuster base plate with screws, Item 4, supplied.

5.0 Install B-225H Housing

5.1 Position housing into trunnion rings - anode side toward front of gantry. Check very carefully for proper housing and trunnion liner fit into trunnion ring grooves or a housing tilt will occur. Install upper trunnion rings, Items 2 and 10.

6.0 Install HE-580 Heat Exchanger

6.1 Install HE-580 heat exchanger. Use original nuts and lockwashers, **Locktight is required on all Heat Exchanger hardware.**

NOTE: After installation of B-225H Housing and HE-580 Heat Exchanger, verify balance. An additional counterbalance weight may be required.

ILLUSTRATIVE VIEW - FIG. 1

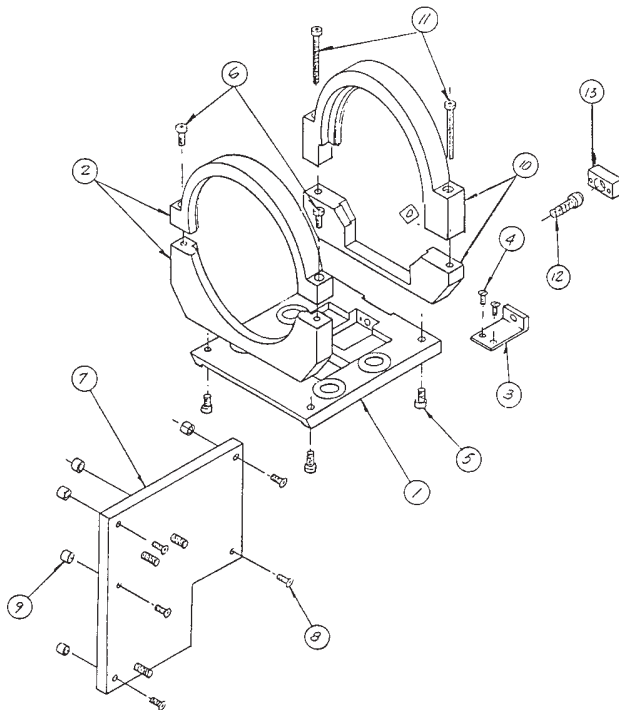

1	746891	Z AXIS ADJUSTING BLOCK	13
1	746823	ADJUSTING SCREW ASSY	12
2	221091N	5/16 -18 UNC SOC HD CAP SCR x 3" LG	11
1	746580	TRUNNION RING SET (PICKER) - LEFT SIDE	10
5	749642	SPACER	9
5	050268N	1/4 - 20 x 1 LG FHMS ST STL SCR Phillips	8
1	746494	MOUNTING PLATE	7
2	510022N	5/16 -18 UNC SOC HD CAP SCR x 1" LG	6
4	072117N	5/16 -18 UNC SOC HD CAP SCR x 3/4" LG	5
2	221046N	10 - 32 UNF FLAT HD Bolt x 1/2" LG	4
1	746492	PICKER ADJUSTING TONGUE	3
1	745803	TRUNNION RING SET (PICKER) - RIGHT SIDE	2
1	745802	TRUNNION RING MOUNT	1

Stator - Wiring Diagram
Stator - Schéma de Câblage
Stator - Drahtfarbentabelle
Bovina - Diagramas

Spécificités et Caractéristiques du Stator
Statorenleistungen und Merkmale
Características y Clarificación de la Bovina

Wire Color	Description
Couleurs des Branchements	Description
Kabelfarben	Beschreibung
Cable de Color	Descripción
1 Green	Phase Shift
Vert	Stator de Changement de Phase
Grün	Veränderliche Statorphase
Verde	Cambio de Fase del Estator
2 Black	Phase
Noir	Phase
Schwarz	Phase
Negro	Fase
3 White	Common
Blanc	Neutre
Weiss	Neutral
Blanco	Común
4 Red	Center Section
Rouge	Section Centrale
Rot	Mittelteil
Rojo	Sección Central
5 Blue	Housing Ground
Bleu	Masse de la Gaine
Blau	Masse des Gehäuses
Azul	Encaje a Tierra
8 White/Black	Thermal Switch
Blanc/Noir	Switch Thermique
Weiss/Schwarz	Thermoschalter
Blanco/Negro	Interruptor Termal
9 Red/Black	Thermal Switch
Rouge/Noir	Switch Thermique
Rot/Schwarz	Thermoschalter
Rojo/Negro	Interruptor Termal

Stator Drive Frequency	
Fréquence d'entraînement du stator	
Statorantrieb Frequenz	
Frekuensi de la impulsión del estator	RPM
50/60 Hz	2800/3400 ±10%
150/180 Hz	8200/9600 ±10%

WIRING DIAGRAM - FIG. 2

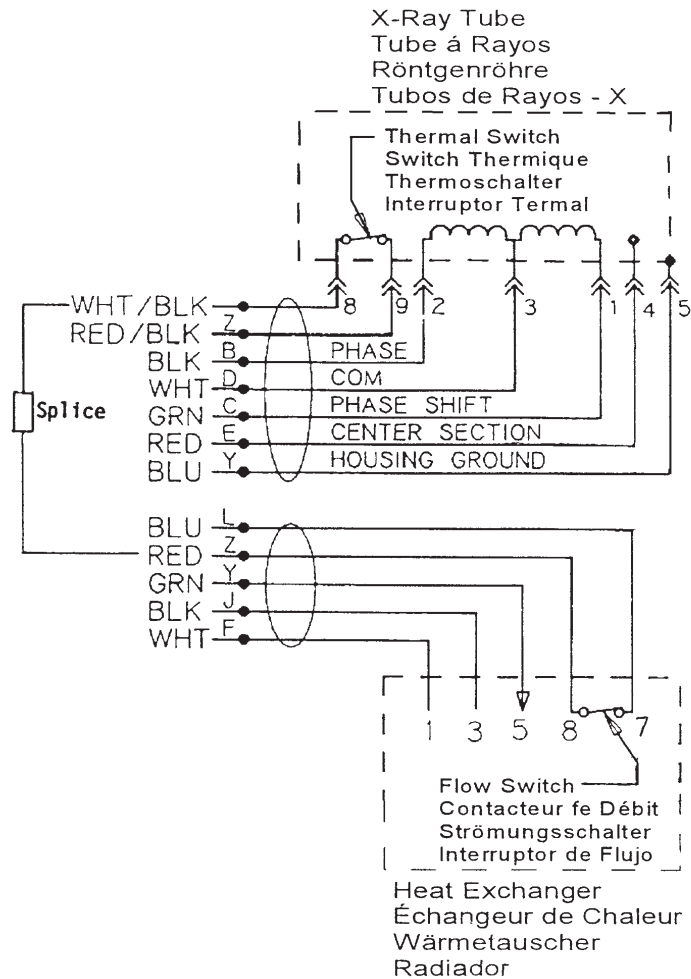

Stator Type:		
Stator Coil Resistance:		
Black to White	14.0 Ohms ±15%	
Green to White	46.0 Ohms ±15%	
Black to Green	60.0 Ohms ±15%	
Starter Voltage:	Start	Run
50/60 Hz	220 VAC	70 VAC
150/180 Hz	350 VAC	85 VAC
Time to Full Speed:		
50/60 Hz	0 - 3400 RPM	8.5 sec
150/180 Hz	0 - 9500 RPM	18 sec
X-Ray Tube Assembly:	GS-2096/B-225H IEC 60601-2-28	

Genre Stator:		
Résistance de la bobine du stator: (résistance ohmique)		
Noir - Blanc	14,0 Ohms ±15%	
Noir - Blanc	46,0 Ohms ±15%	
Vert - Blanc	46,0 Ohms ±15%	
Noir - Vert	60,0 Ohms ±15%	
Tension de démarrage:		
50/60 Hz	220 alternatif au démarrage	
50/60 Hz	70 alternatif en maintien	
150/180 Hz	350 alternatif au démarrage	
	85 alternatif en maintien	
Temps pour atteindre la vitesse maximum:		
50/60 Hz	de 0 à 3400 trs/mn	8.5 sec
150/180 Hz	de 0 à 9500 trs/mn	18 sec
Ensemble radiogène:	GS-2096/B-225H CEI 60601-2-28	

Stator typ:		
Stator - Spulenwiderstand (résistance ohmique)		
Schwarz - Weiss	14.0 Ohms ±15%	
Grün - Weiss	46.0 Ohms ±15%	
Schwarz - Grün	60.0 Ohms ±15%	
Spannungen:	Anlauf	Weiterlauf
50/60 Hz	220 VAC	70 VAC
150/180 Hz	350 VAC	85 VAC
Hochlaufzeit:		
50/60 Hz	0 - 3400 u/min	8.5 sek
150/180 Hz	0 - 9500 u/min	18 sek
Röntgenstrahler:	GS-2096/B-225H IEC 60601-2-28	

Tipo de la Bovina:		
Resistencia del Rollo de la Bovina:		
Negro a Blanco	14.0 Ohms ±15%	
Verde a Blanco	46.0 Ohms ±15%	
Negro a Verde	60.0 Ohms ±15%	
Voltage de la Obtenida:	Empezar	Funcionar
50/60 Hz	220 VAC	70 VAC
150/180 Hz	350 VAC	85 VAC
Tiempo Para la Velocidad Maxima:		
50/60 Hz	0 - 3400 RPM	8.5 Segundo
150/180 Hz	0 - 9500 RPM	18 Segundo
Ensamblaje de Tubo de Rayos X:	GS-2096/B-225H IEC 60601-2-28	

7.0 Wiring

7.1 Dress stator and heat exchanger cable to “Inboard Drive Chassis”.

7.1.1 Wiring Connections Housing (Also See Figure #2):

TB301		
Black	B	Phase
White	D	Common
Green	C	Phase Shift
Red	E	Metal Center
Blue	Y	Housing Ground

7.1.2 Wiring Connections Heat Exchanger

White	F	AC Power
Black	J	AC Power
Green	Y	Ground
Blue	L	Flow Switch
Red	Connect in series with the white/black wire from thermal switch on housing. Connect second wire from housing thermal switch to TB301 - Z. See Figure #2.	

NOTE: Wire from TB301-E runs to J515-5 (ground) at grid tank (Big Shot system only). The wire will be a current carrier during an exposure. Do not remove J515-5 from ground.

8.0 Heat Exchanger Fuse

8.1 Heat exchanger fuse - replace 2-amp fuse, F106, in remote electronics cabinet with a 5-amp fuse.

9.0 Starter - The GS-2096 can be run at either 10,000 or 3400

RPM. Varian recommends that the GS-2096 be run at 3400 RPM to extend tube bearing life. The following modifications for Big Shot systems are only required if 3400 RPM operations is desired. These changes will include creating an 8-1/2 second rotor boost time for standard speed anode rotation. The changes will give us the required delay for SS04, Rev. C-2 software.

9.1 General X-Ray Interface (Wire Wrap Version, 173507).

9.1.1 Remove the following wire wraps:

- A7 pin 14 to J63
- C11 pin 12 to J57
- B7 pin 2 to A11 pin 13
- A14 pin 12 to A14 pin 5
- A14 pin 5 to A18 pin 5

9.1.2 Add the following wires:

- A18 pin 4 to A14 pin 5
- A18 pin 5 to A14 pin 12

9.2 General Interface (P.C.B. Version, 173533).

9.2.1 Remove the following:

- R52, Q7, R21 and lift U19 pin 13 out of socket

9.2.2 Add the following wire:

- U7-11 to flying lead U19 pin 13

9.3 High Speed Starter

9.3.1 Remove DC brake from circuit.

- 9.3.1.1 Disconnect plugs 520 and 521 from brake cabinet and install directly from power module to high speed starter.

9.3.2 Replace R46 on rotor logic board with 500K trim pot. (**NOTE:** If replacing a Mega HD tube, R21 should be a 500K pot and can be used.)

9.3.3 Adjustments

Starter Voltage	220 VAC
Run Voltage	70 VAC
Start to Run Delay	8 1/2 sec (R46)

9.4 Software

9.4.1 Configure DESC for “Mega HD” and “Hi Speed”

10.0 New Tube Seasoning Procedure - (Must be performed prior to operating tube above 100 kVp.)

10.1 Use this procedure for new tubes or tubes that have been inactive over seven days.

10.2 X-Ray Control Cabinet

10.2.1 Select 80 kV, 150 mA, 6 seconds.

10.2.2 Select large focal spot.

10.2.3 Make 18 exposures - 20 seconds between exposures.

10.2.4 Allow tube to cool **30 Minutes**.

10.2.5 In 10 kV steps, make exposures to 130 kV, 1 exposure at each step.

11.0 Spellman Generator Modifications (See figure 3)

11.1 Connection of Metal Center Section

- 11.1.1 Install GS-2096 in gantry as outlined in the installation procedure of this brochure.
- 11.1.2 Locate J302 in the left side of the gantry.
- 11.1.3 Make connection to J302 (black/white wire).
- 11.1.4 Run about 150 feet or 16 gage wire from the connection made in 11.1.3 to inside the HV chassis of the Spellman Generator. (left side cabinet) (Schematic 440143-001, 440159-001)
- 11.1.5 Locate the Anode HV Module on the right side inside the HV chassis.
- 11.1.6 Look on the backside of module for a screw stud with a blue wire on it which connects to the LV feedback PCB J1-4. (Schematic 340098-001).
- 11.1.7 Add a spade lug to this end of the wire and connect it to the screw stud. This is the **Anode Shield**.
- 11.1.8 This connection will add the metal center section current back into the current sensing network thus preventing a current imbalance error.
- 11.1.9 Make manual exposure at all mA and kVp levels. Verify correct operation, if kVp imbalance occurs continue to Part 11.2.

11.2 kVp Imbalance Adjustment (do only if kVp imbalance occurs).

- 11.2.1 Locate R5, Cathode KVP TP CAL, on the Analog Control BD in the Control Chassis of the Spellman Generator. (Schematic 440147-002 Sheet 2)
- 11.2.2 Adjust R5 until kVp imbalance error is corrected.
- 11.2.3 Make manual exposure at all kVp and mA levels to verify correct operation.
- 11.2.4 If kVp imbalance still occurs, additional turns may need to be made to R5.

11.3 180 HZ Noise Measurement

- 11.3.1 Using the DPS program measure the 180HZ noise.
- 11.3.2 If the 180 HZ noise is out of specification a 68 uf capacitor should be added in parallel with C5 on the Low Voltage Feed Back P.C.B. The negative lead should be connected to E1.

SPELLMAN WIRING - FIG. 3

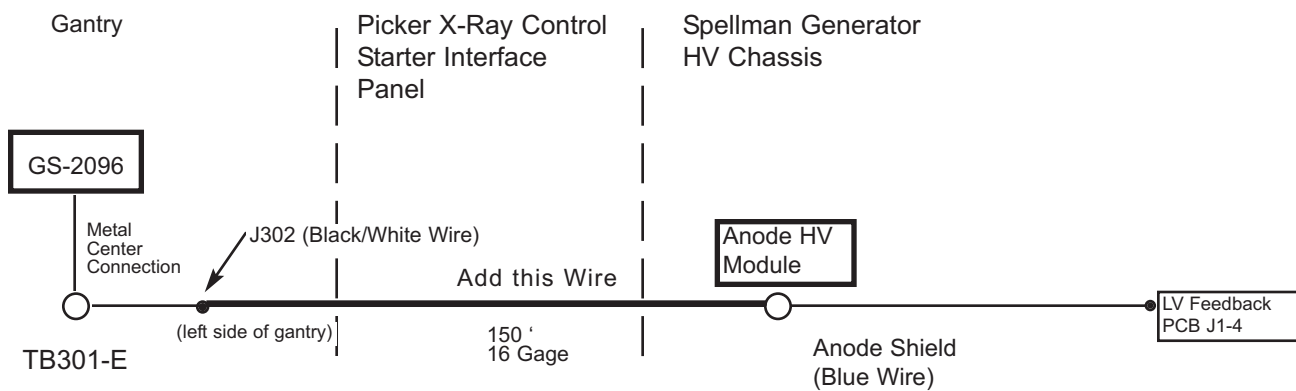

Abaques d'Échauffement et de Refroidissement de L'Anode
Anoden Aufheiz und Abkühlkurven
Curvas de Calentamiento y Enfriamiento del Anodo

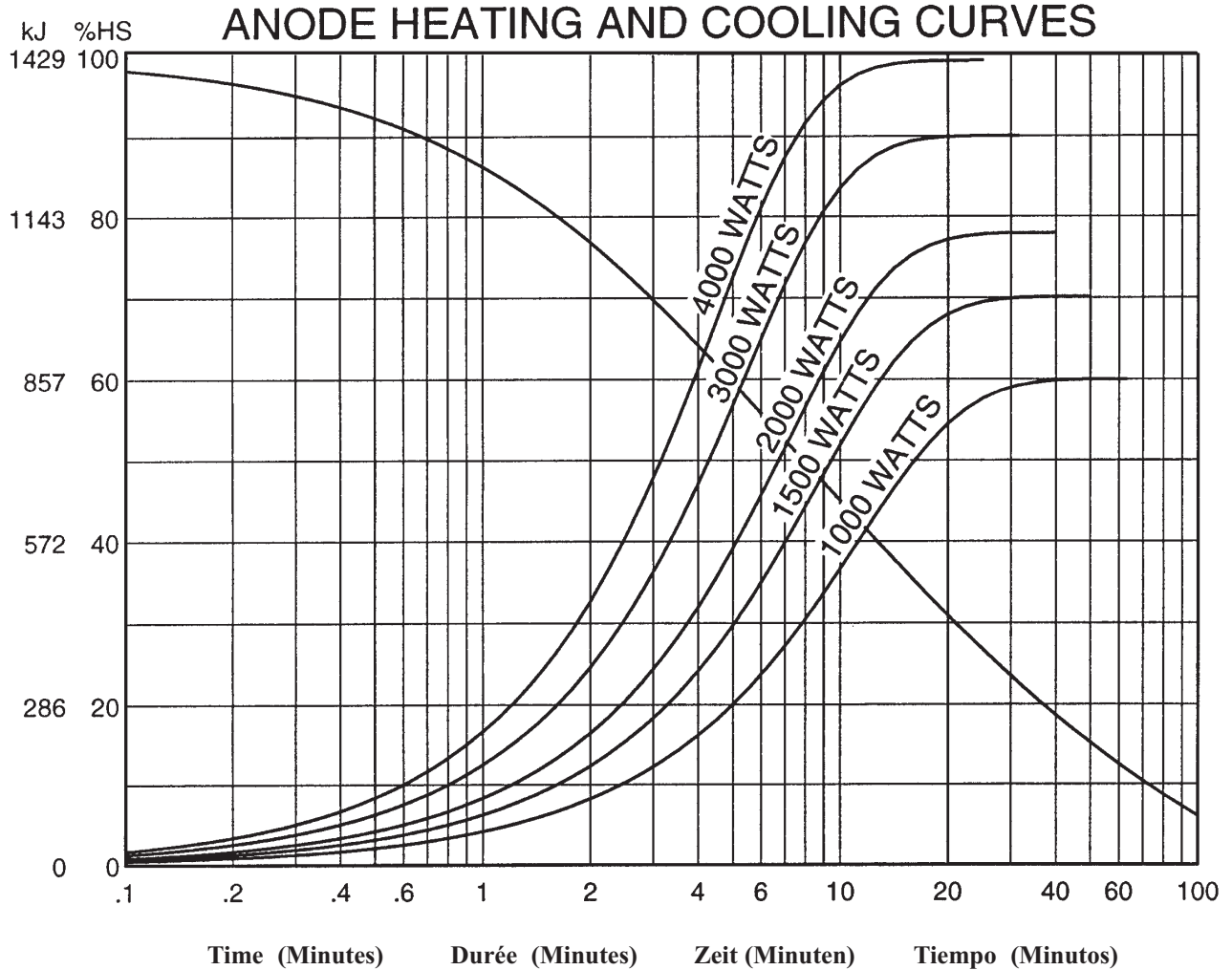

Note:
1. Heating and cooling curves reflect maximum tube performance. Tube operation is ultimately limited by system software control.

Remarque:
1. Les abaques d'échauffement et de refroidissement représentent des valeurs maximales. L'utilisation du tube est finalement limitée par le logiciel du système.

Anmerkungen:
1. Die Angaben stellen die höchstzulässigen Betriebswerte dar. Der technische Betrieb muß im Rahmen der Belastungs- und Abkühlkennlinien erfolgen.

Nota:
1. El máximo poder del tubo es reflectada en el diagrama de enfriamiento y calentamiento del encaje ensamblado. La operación del tubo es ultimamente limitada por el control del sistema programado.

